

EXAMINED BY : <i>Jony Chen</i>	EMERGING DISPLAY TECHNOLOGIES CORPORATION	FILE NO . CAS-10069
APPROVED BY: <i>David Chang</i>		ISSUE : NOV.17,1999
		TOTAL PAGE : 10
		VERSION : 2

CUSTOMER	ACCEPTANCE	SPECIFICATIONS
----------	------------	----------------

MODEL NO. :

32F10(CCFL TYPES)

FOR MESSRS :

CUSTOMER'S APPROVAL

DATE :

BY :

EMERGING DISPLAY
TECHNOLOGIES CORPORATION

MODEL NO. 32F10(CCFL TYPES)	VERSION 2
--------------------------------	--------------

RECORDS OF REVISION	DOC . FIRST ISSUE FEB.17,1998
---------------------	----------------------------------

DATE	REVISED PAGE NO.	SUMMARY
NOV.17,1999	1~3,6	THE ENTIRE PAGES REVISED

NUMBERING SYSTEM

Polarizer Mode	Backlight	Code value
Transflective	CCFL	D
Transmissive	CCFL	C

Backlight Color	Code Value
White	W

E W 3 2 F 1 0 B C W U

Viewing direction
NIL. : 6 o'clock
U : 12 o'clock

LCD type + LCD color	Code Value
STN + Gray	G
STN + Blue	B
FSTN + White	F
FSTN + Black	N

TABLE OF CONTENTS

NO.	ITEM	PAGE
=====		
1.	GENERAL SPECIFICATIONS -----	1
2.	MECHANICAL SPECIFICATIONS -----	1
3.	ABSOLUTE MAXIMUM RATINGS -----	2
4.	ELECTRICAL CHARACTERISTICS -----	3
5.	TIMING CHARACTERISTICS -----	4~5
6.	OPTICAL CHARACTERISTICS -----	6
7.	OUTLINE DIMENSION -----	7
8.	BLOCK DIAGRAM -----	8
9.	DETAIL DRAWING OF DOT MATRIX -----	9
10.	INTERFACE SIGNALS -----	9
11.	POWER SUPPLY -----	10

1. GENERAL SPECIFICATIONS

1.1 GENERAL SPECIFICATIONS
PLEASE REFER TO :

CUSTOMER ACCEPTANCE STANDARD SPECIFICATIONS :

E U - 0 0 2 A

1.2 THIS INDIVIDUAL SPECIFICATION IS PRIOR TO GENERAL SPECIFICATIONS .

2. MECHANICAL SPECIFICATIONS

- | | | |
|-------------------------|-------|----------------------------------|
| (1) NUMBER OF DOTS | ----- | 320W * 240H DOTS |
| (2) MODULE SIZE | ----- | 167.1W * 109.0H * 11.0D(max.) mm |
| (3) EFFECTIVE AREA | ----- | 120.0W * 90.0H mm |
| (4) ACTIVE AREA | ----- | 115.17W * 86.37H mm |
| (5) DOT SIZE | ----- | 0.33W * 0.33H mm |
| (6) DOT PITCH | ----- | 0.36W * 0.36H mm |
| (7) LCD TYPE * | | |
| (8) DRIVING METHOD | ----- | 1 / 240 DUTY MULTIPLEX DRIVE |
| (9) VIEWING DIRECTION * | | |
| (10) BACKLIGHT | ----- | CCFL |

* PLEASE REFER TO NUMBERING SYSTEM .

3. ABSOLUTE MAXIMUM RATINGS

3.1 ELECTRICAL ABSOLUTE MAXIMUM RATINGS .

PARAMETER	SYMBOL	MIN .	MAX .	UNIT	REMARK
POWER SUPPLY FOR LOGIC	VDD — VSS	0	6.0	V	
POWER SUPPLY FOR LCD DRIVING	VDD — VEE	0	27.0	V	
INPUT VOLTAGE	VI	VSS	VDD	V	
STATIC ELECTRICITY	—	—	100	V	NOTE (1)

NOTE (1) : TEST METHOD AND CONDITIONS :
AFTER CHARGING UP 200 PF CAPACITOR BY STATED VOLTAGE ,
THE CAPACITOR IS CONNECTED WITH INTERFACE PINS OF THE
MODULE .

3.2 ENVIRONMENTAL ABSOLUTE MAXIMUM RATINGS .

I T E M	OPERATING		STORAGE		REMARK
	MIN .	MAX .	MIN .	MAX .	
AMBIENT TEMPERATURE	-10℃	60℃	-20℃	70℃	NOTE (2),(3),(4)
HUMIDITY	—	85 % RH	—	85 % RH	WITHOUT CONDENSATION
VIBRATION	—	2.45 m/s ² (0.25 G)	—	11.76 m/s ² (1.2 G)	10~100 HZ XYZ DIRECTIONS 1 Hr. EACH
SHOCK	—	29.4 m/s ² (3 G)	—	490.0 m/s ² (50 G)	10 mSECONDS XYZ DIRECTIONS 1 TIME EACH
CORROSIVE GAS	NOT ACCEPTABLE		NOT ACCEPTABLE		

NOTE (2) : Ta AT -20℃ : 48HR MAX.
70℃ : 168HR MAX.

NOTE (3) : BACKGROUND COLOR CHANGES SLIGHTLY DEPENDING ON AMBIENT
TEMPERATURE THIS PHENOMENON IS REVERSIBLE .

NOTE (4) : CCFL BACKLIGHT IS NOT AVAILABLE TO FUNCTION BELOW 0℃

4. ELECTRICAL CHARACTERISTICS

Ta = 25 °C

VDD = 5.0 V

PARAMETER	SYMBOL	CONDITION	MIN.	TYP.	MAX.	UNIT
POWER SUPPLY VOLTAGE FOR LOGIC	VDD — VSS	—	4.75	5.0	5.25	V
POWER SUPPLY VOLTAGE FOR LCD DRIVE	VEE — VSS	—	-21.5	-22.0	-22.5	V
INPUT VOLTAGE NOTE (1)	VIH	H LEVEL	0.8*VDD	—	—	V
	VIL	L LEVEL	—	—	0.2*VDD	V
OUTPUT VOLTAGE NOTE (1)	VOH	H LEVEL	2.4	—	—	V
	VOL	L LEVEL	—	—	VSS+0.4	V
POWER SUPPLY CURRENT FOR LOGIC NOTE (2)	IDD	VDD-VSS = 5.0 V VDD-VEE = 22.0 V	—	3.0	—	mA
POWER SUPPLY CURRENT FOR LCD DRIVE NOTE (2)	IEE	VDD-VSS = 5.0 V VDD-VEE = 22.0 V	—	2.8	—	mA
RECOMMENDED LCD DRIVING VOLTAGE NOTE (3)	VDD-V0 ∅ = 10° , θ = ** DUTY = 1/240	Ta = -10 °C	—	25.1	—	V
		Ta = 25 °C	—	23	—	V
		Ta = 60 °C	—	21.3	—	V
CLOCK OSCILLATION FREQUENCY	f FLM	—	70	75	80	HZ
POWER SUPPLY FOR CCFL	VOLTAGE	VCCFL	—	300	—	Vrms
	FREQUENCY	f CCFL	—	30K	—	HZ
	CURRENT	IL	—	5	—	mA
	LIFE TIME	L	IL = 5.0mA	15000	20000	—

** θ = 0° WHEN VIEWING DIRECTION IS 6 O'CLOCK .
θ = 180° WHEN VIEWING DIRECTION IS 12 O'CLOCK .

NOTE (1): APPLIED TO TERMINALS M , FLM , CL1 , CL2 , D0~D3 , DISPOFF .

NOTE (2): THE DISPLAY PATTERN IS ALL "OFF"/ "ON" .

NOTE (3): RECOMMENDED LCD DRIVING VOLTAGE MAY FLUCTUATE ABOUT ± 1.0V BY EACH MODULE .

5. TIMING CHARACTERISTICS
5.1 INTERFACE TIMING

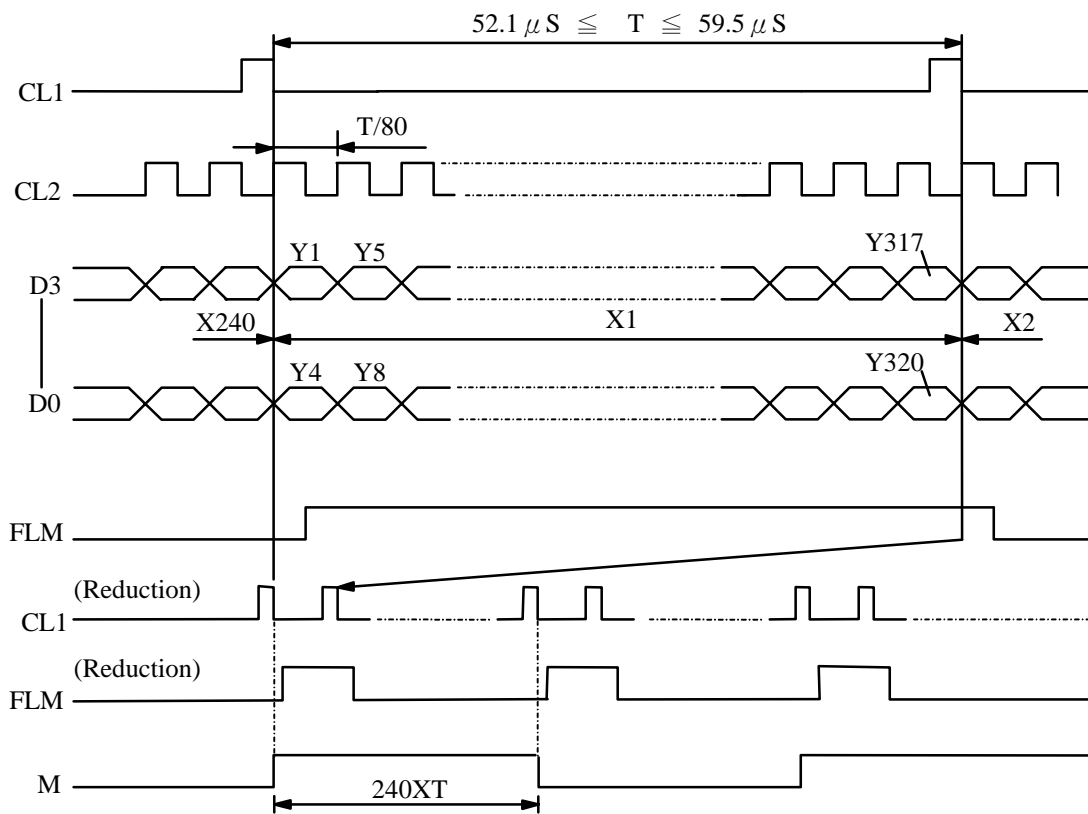

5.2 SWITCHING CHARACTERISTICS

PARAMETER	SYMBOL	MIN.	TYP.	MAX.	UNIT
Frequency of maximum clock	fcp	—	—	8	MHZ
CL1 , CL2 , pulse width	tw	45	—	—	ns
Rise , fall time	tr,tf	—	—	15	ns
Data setup time	tDSU	20	—	—	ns
Data hold time	tDHD	20	—	—	ns
CL1 setup time	tLSU	80	—	—	ns
CL1 → CL2 time	tLC	80	—	—	ns
FLM setup time	tsetup	100	—	—	ns
FLM hold time	thold	100	—	—	ns
M delay time	tDF	—	—	300	ns

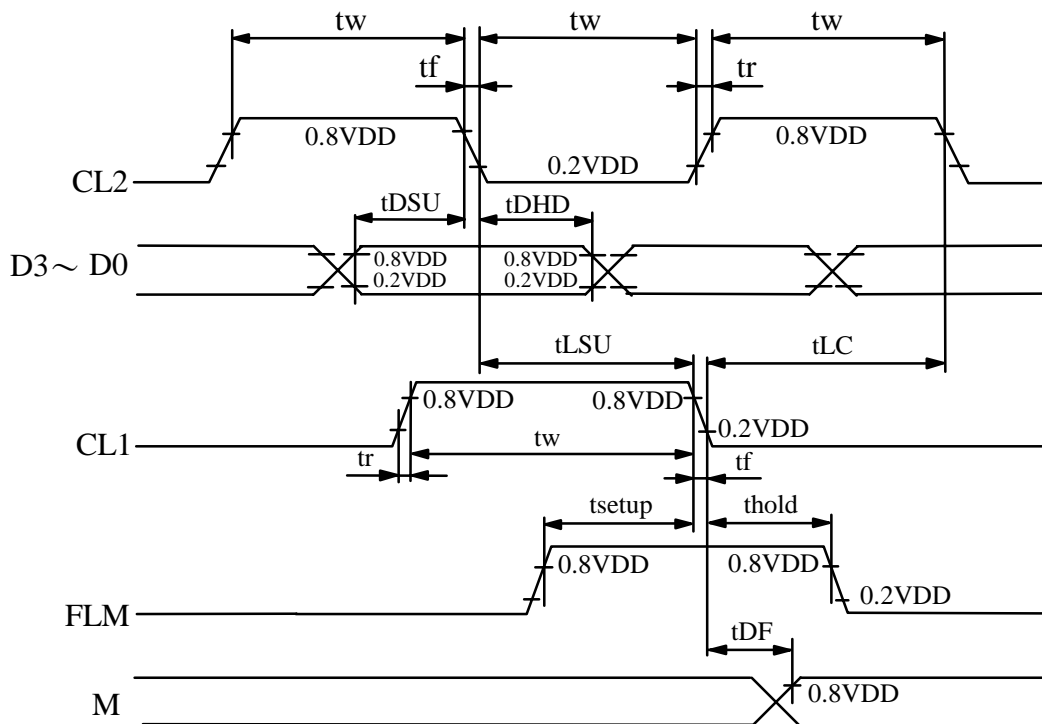

6. OPTICAL CHARACTERISTICS

Ta = 25 °C

VDD = 5.0 V

I T E M		SYMBOL	CONDITION	MIN.	TYP.	MAX.	UNIT	NOTE
VIEWING AREA	STN	∅2 - ∅1	K ≥ 2.0	—	40	—	deg.	1
	FSTN			—	50	—	deg.	1
CONTRAST RATIO	STN	K	∅ = 10 ° θ = **	—	10	—	—	1
	FSTN			—	20	—	—	1
RESPONSE TIME	tr (rise)	∅=10° θ = **	Ta = -10 °C	—	2149	—	ms	1
			Ta = 25 °C	—	228	—		
			Ta = 60 °C	—	124	—		
	tf (fall)		Ta = -10 °C	—	1709	—		
			Ta = 25 °C	—	191	—		
			Ta = 60 °C	—	96	—		
BRIGHTNESS OF BACKLIGHT	B	—	300	—	—	cd / m ²	2	
RISE TIME OF BACKLIGHT	TC	—	—	5	—	MINUTE		
BRIGHTNESS UNIFORMITY	—	—	—	—	—	20	%	3, 4

** θ = 0° WHEN VIEWING DIRECTION IS 6 O'CLOCK.

θ = 180° WHEN VIEWING DIRECTION IS 12 O'CLOCK.

NOTE (1) : PLEASE REFER TO :
CUSTOMER ACCEPTANCE STANDARD SPECIFICATIONS. (EU - 001A)

NOTE (2) : POLARIZER MODE : TRANSMISSIVE

NOTE (3) : MEASUREMENT OF THE FOLLOWING 9 PLACES ON THE DISPLAY.
DEFINITION OF THE BRIGHTNESS TOLERANCE .

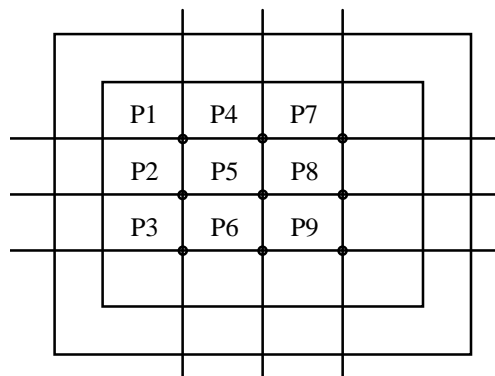

NOTE (4) : BRIGHTNESS UNIFORMITY IS DEFINED AS FOLLOWING

$$\sum X = \left[\frac{(\text{MAXIMUN BRIGHTNESS OR MINIMUN BRIGHTESS}) - \text{AVERAGE BRIGHTNESS}}{\text{AVERAGE BRIGHTNESS}} \right] \times 100\%$$

7. OUTLINE DIMENSION

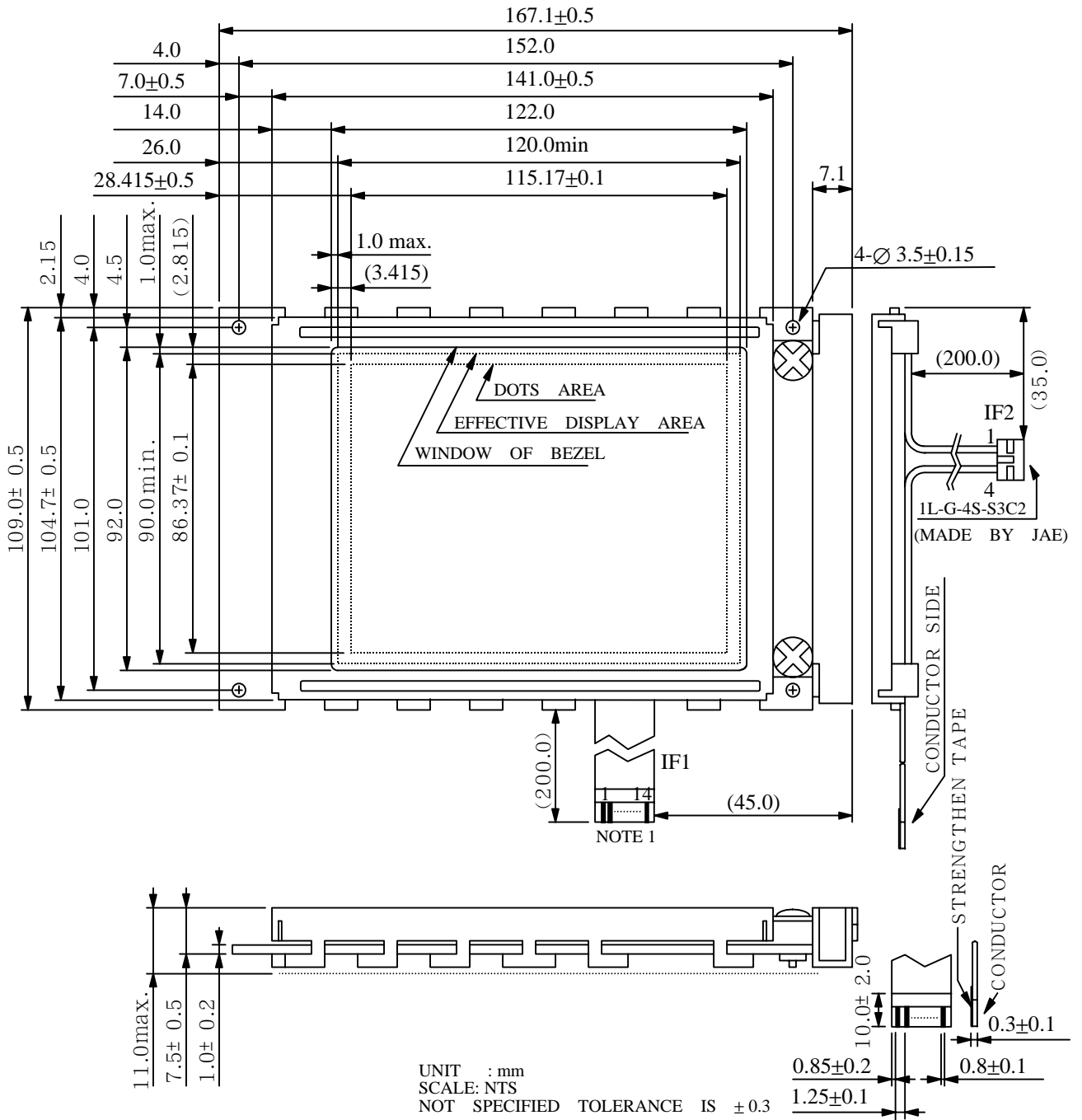

NOTE 1 : MAKER : SUMITOMO (JAPAN)

8. BLOCK DIAGRAM

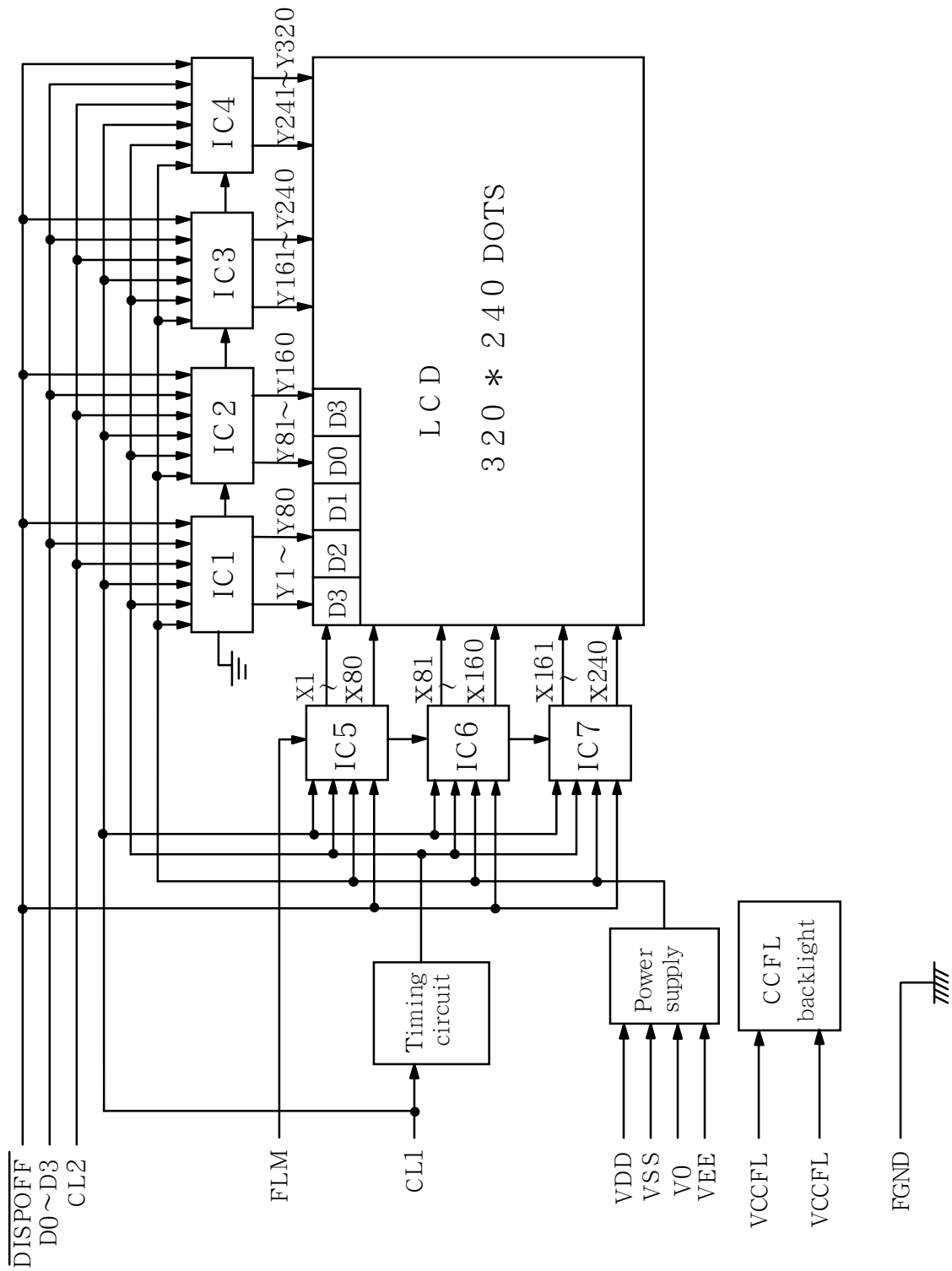

9. DETAIL DRAWING OF DOT MATRIX

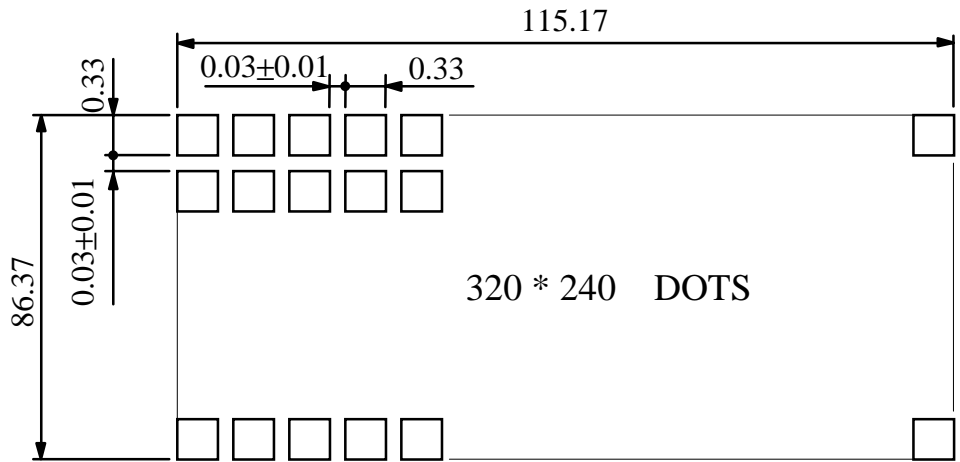

UNIT : mm
SCALE : NTS
NOT SPECIFIED TOLERANCE IS ± 0.1

10. INTERFACE SIGNALS

IF1 :

PIN NO	SYMBOL	LEVEL	FUNCTION
1	D0	H / L	DISPLAY DATA
2	D1	H / L	
3	D2	H / L	
4	D3	H / L	
5	$\overline{\text{DISPOFF}}$	H / L	H : DISPLAY ON , L : DISPLAY OFF
6	FLM	H	THE FLM SIGNAL INDICATING THE BEGINNING OF EACH DISPLAY CYCLE
7	NC	—	NO CONNECTION
8	CL1	H → L	DISPLAY DATA LATCH
9	CL2	H → L	DISPLAY DATA SHIFT
10	VDD	—	POWER SUPPLY FOR LOGIC CIRCUIT
11	VSS	—	GROUND
12	VEE	—	POWER SUPPLY FOR LCD DRIVING
13	VO	—	OPERATING VOLTAGE FOR LCD DRIVING
14	FGND	—	FRONT PANEL GROUND

IF2 :

INTERFACE	PIN	SINGAL	VEVEL	FUNCTION
CCFL	1	VCCFL	—	POWER SUPPLY FOR CCFL DRIVING
	2~3	NC	—	NO CONNECTION
	4	VCCFL	—	POWER SUPPLY FOR CCFL DRIVING

1 1 . POWER SUPPLY

1 1 . 1 POWER SUPPLY FOR LCM

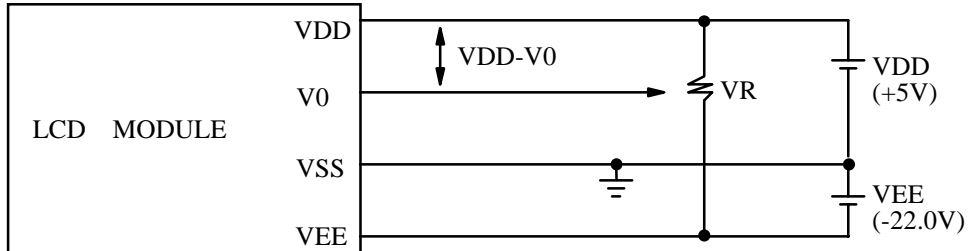

VDD-V0 : LCD DRIVING VOLTAGE
VR : 20K Ω

1 1 . 2 POWER SUPPLY FOR CCFL BACK - LIGHT

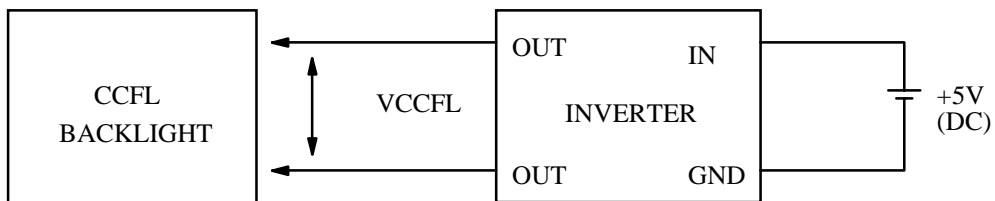

RECOMMENDED INVERTER : IA-EM02A

1 1 . 3 TIMING OF POWER SUPPLY AND INTERFACE SIGNAL

